

SOLUTION

Electromobility

Surge protection of charging stations



Nowadays, environmental awareness and cleanliness of the environment are emphasized. The field fitting well with this trend – Electromobility – is therefore developing very quickly. In order to lower emissions into the atmosphere, the number of vehicles with combustion engines is reduced by replacing them by electric vehicles. These trends involve the necessary development of a sufficiently large network of charging stations with safe and reliable operation. The safe and reliable operation can be ensured by proper overvoltage protections. Charging station can be stand-alone or located within a building (garage). This material is primary concerned with stand-alone stations. Stations located in buildings will be protected according to standard rules. You can find these rules in our guide - Surge protection of LV systems.

Why to Protect?

Due to direct and indirect lightning strikes, lightning electromagnetic pulses (LEMPs) of up to several thousands of volts can be superposed in the grid of the charging station by the induction or the direct galvanic interconnection. Similar overvoltage phenomena of a lower energy can also occur in installations with large inductive loads in form of switching electromagnetic pulses (SEMPs).

These overvoltage pulses can damage the charging station, or even the connected, just charging vehicle. For this reason, charging stations should be equipped with an appropriate overvoltage protection to reduce the risk of damage of various devices included in the charging station. The cost of the overvoltage protection is only a fraction of the purchase price of the protected equipment.

What to Protect?

- Rectifier for the DC charging output
- Rectifier for powering the control unit
- Battery – in case of charging station with energy accumulation
- Communication between the control unit and the charging connector (e.g. RS-485)
- Signal from the charging connector (e.g. temperature measurement)
- Communication between antenna and control unit (e.g. Ethernet) for data cable longer than 1 m

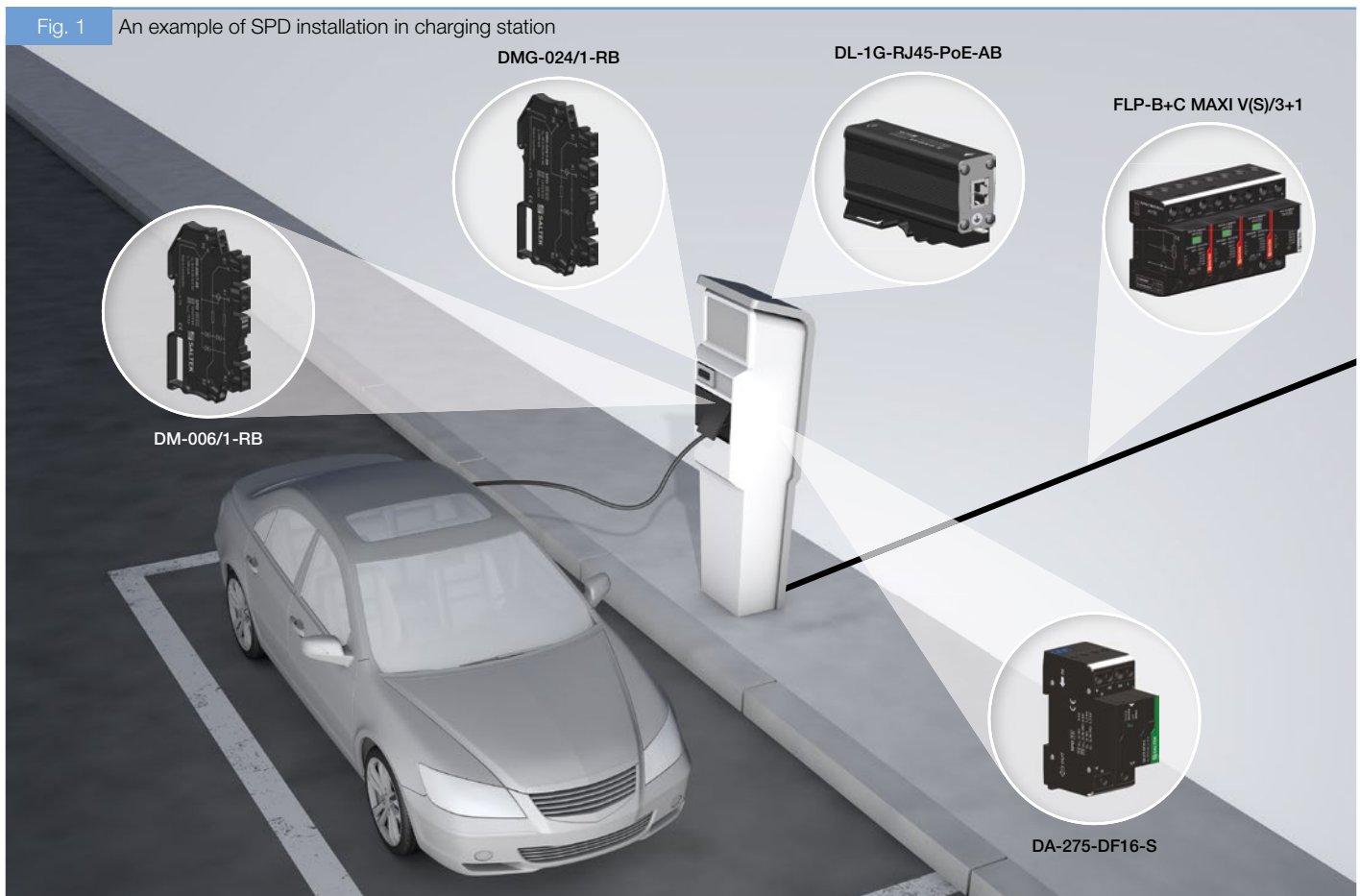

Some of the charging stations have the possibility of accumulating energy. For these types of stations surge protection system does not change.

Fig. 2 Block diagram of the charging station

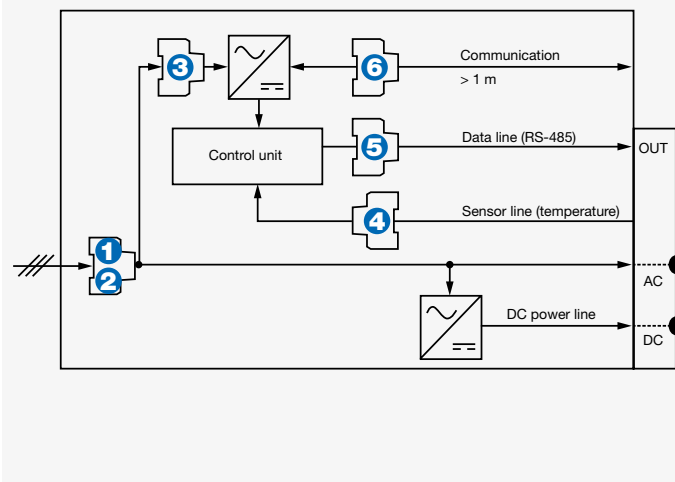
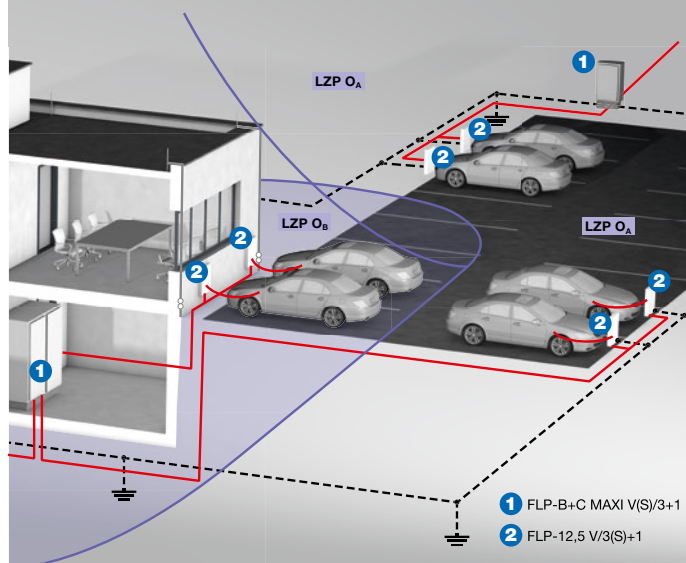

Fig. 3 SPD selection by lightning protection zones



Recommended SPDs for charging stations

1 FLP-B+C MAXI V(S)/3+1

Three-pole combined high performance lightning current arrester. The use for external wiring at the beginning of installation.

Connection	Suitable networks	U _c	I _{imp} (10/350 μs)	I _n (8/20 μs)	I _{max} (8/20 μs)	Remote signalling	Ordering number
3+1	TN-S, TT	275 V	25 kA	30 kA	60 kA	Yes	8595090535720

2 FLP-12,5 V/3(S)+1

Three-pole combined high performance lightning current arrester. The use for the cable inlet in the ground.

Connection	Suitable networks	U _c	I _{imp} (10/350 μs)	I _n (8/20 μs)	I _{max} (8/20 μs)	Remote signalling	Ordering number
3+1	TN-S, TT	275 V	12.5 kA	30 kA	60 kA	Yes	8595090534280

3 DA-275-DF16-S

Overvoltage protection of the type 3 with an integrated noise-suppressing RF filter.

Connection	Suitable networks	U _c	I _L	I _n (L+N-PE) (8/20 μs)	U _{oc} (8/20 μs) (L+N-PE)	Remote signalling	Ordering number
Symmetric	TN, TT	275 V	6 A	5 kA	25 V	Yes	8595090557227

4 DMG-024/1-RB

Two-stage overvoltage protection of signal lines (e.g. temperature).

Location	Number of lines	U _c	I _L	I _n (C2)	U _p (C3) core-core	Floating	Ordering number
ST 2+3	1	25 V	0.5 A	5 kA	25 V	Yes	8595090560623

5 DM-006/1-RB

Two-stage overvoltage protection of signal lines (e.g. RS-485).

Location	Number of lines	U _c	I _L	I _n (C2)	U _p (C3) core-core	Floating	Ordering number
ST 2+3	1	8.5 V DC	0.5 A	5 kA	12 V	No	8595090560579

6 DL-1G-RJ45-PoE-AB

Two-stage Ethernet overvoltage protection combined with supply protection over this line. For cable longer than 1 m.

Location	Network type	U _c (line/supply)	I _L (line/supply)	I _n (C2) (8/20 μs)	U _p (C3) core-core	U _p (C3) core-PE	Ordering number
ST 1+2+3	1G	8,5 / 58 V DC	0.5 / 1.5 A	0.15 kA	60 / 90 V	500 V	8595090561484

Sales and technical support:

SALTEK TRADE s.r.o.

Vodňanská 1419/226
198 00 Praha 9 – Kyje
Czech Republic
Phone: +420 272 942 470
E-mail: trade@saltek.cz
www.saltek.eu/en

Manufacture and headquarter:

SALTEK s.r.o.

Drážďanská 85
400 07 Ústí nad Labem
Czech Republic
Phone: +420 475 655 511
Fax: +420 475 622 213
E-mail: info@saltek.cz
www.saltek.eu

Distributor: